

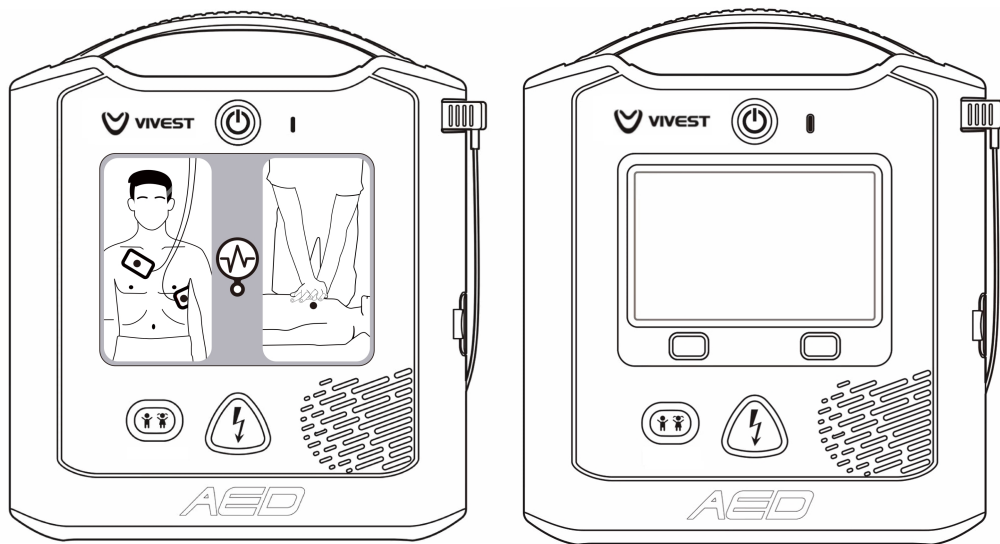

A1/A3

Automated External Defibrillator

User Manual



ViVest Medical Technology Co., Ltd

User Manual (English)

Before Use

Thank you for purchasing this A series Automated External Defibrillator (AED).
Please read this manual carefully before using the device.

Version: 1.1

Revision Date: 2026/05/20



Name: ViVest Medical Technology Co., Ltd.

Address: Unit 401,501, Building No.2, Zone B, SIP Biobay Phase 5, No.21,
Dongyanli Road, Suzhou Industrial Park, 215123 Suzhou, Jiangsu,
PEOPLE'S REPUBLIC OF CHINA.

SRN: CN-MF-000015304 Tel: +86-0512-65730937

Fax: +86-0512-65730937 Email: service@vivest.cn



Name: Shanghai International Holding Corp. GmbH (Europe)

Address: Eiffestrasse 80, 20537 Hamburg, GERMANY

SRN: DE-AR-000000001



CE mark: Indicates that the device complies with the EU 2017/745

Copyright and Statement

This manual applies to the A1/ A3 Automated External Defibrillator.

The copyright of this manual is owned by ViVest Medical Technology Co., Ltd. (hereinafter called "VIVEST"). No organization or individual may reproduce this manual or any of its contents in any form without the company's permission.

The company does not assume any responsibility for any injury caused by failing to follow the instructions, precautions, warnings, or usage instructions in this manual.

The copyright of the software in this product is owned by VIVEST. This software is protected by copyright laws and international treaty provisions that apply throughout the world. Without the permission of the company, any organization or individual may not copy, decompile, reverse engineering, or disassemble this software into a form that people can understand. VIVEST reserves the right to own the software.

For information concerning any of our products, please contact VIVEST.

Illustrations

All illustrations in this manual serve as examples only. The color of AED varies by country and region.

Content

1	General Information	5
1.1	Indications	5
1.2	Contraindications	5
1.3	Intended Use	5
1.4	Service Personnel Requirements	6
1.5	Specifications	6
1.6	Product Features	6
1.7	Product Limitations	6
2	Safety Precautions	7
2.1	Classification of Warning Messages	7
2.2	Warning Messages	7
2.3	Placement of the Device	10
2.4	Side Effects	10
3	Installation and Preparation	11
3.1	Unpacking	11
3.2	Product Overview	11
3.3	Components	11
3.4	Install or Remove the Battery	14
3.5	Connect the Pads	15
3.6	Self-test System	15
4	Use Automated External Defibrillator (AED)	17
4.1	Brief Operation Steps	17
4.2	Operation After Use	19
5	Maintenance and Troubleshooting	21
5.1	Daily Maintenance	21
5.2	Battery Maintenance	23
5.3	Transport	23
5.4	Disposal	23
5.5	Troubleshooting	24
6	Product Warranty	26
7	Cyber Security	27
7.1	Runtime Environment	27
7.2	Data Interface	27
7.3	User Access Control System	27
7.4	Data Exchange Mode	28
7.5	Security Software	29
7.6	Cyber Security Update	29
	Appendix 1 Standard Accessories	30
	Appendix 2 Symbols	31

Appendix 3 Glossaries	33
Appendix 4 Specifications	35
Appendix 5 Defibrillation Waveform	38
Appendix 6 ECG Analysis System	39
Appendix 7 Electromagnetic Conformity Guide	41
Appendix 8 Additional Information	46
Appendix 9 Compatible Accessories	47

1 General Information

The A Series Automated External Defibrillator is a portable device that is applied to patients who have a sudden cardiac arrest (SCA) and will deliver a safe electric shock to those with ventricular fibrillation (VF) or ventricular tachycardia (VT) heart rhythms. It consists of a main unit and a non-rechargeable battery.

This chapter introduces general information on A1/A3. Before using this device, please read this manual carefully to ensure that you have a full understanding of its use and to guarantee the safety of both the patient and the operator.

1.1 Indications

A1/A3 should be applied when the patient is in cardiac arrest and has the following symptoms at the same time:

- Unconscious
- No breathing or abnormal breathing
- Unresponsiveness

1.2 Contraindications

A1/A3 should not be used if the patient is responsive or conscious.

1.3 Intended Use

1.3.1 Intended Purpose

Automated External Defibrillator (AED) is indicated for use on patients with suspected Sudden Cardiac Arrest (SCA) who are unconscious, unresponsive and not breathing or breathing abnormally.

1.3.2 Intended Patient Population

The device can be used for adult or pediatric patients. For patients under 8 years of age or less than 25kg, use child mode. For the others, use adult mode. If the age or weight of the patient is uncertain, do not delay the treatment, use adult mode.

1.3.3 Intended Users

The device is intended for use by responders who have been trained in Basic Life Support (BLS), Advanced Life Support (ALS), or another physician-authorized emergency medical response program, or it can be used under the guidance of emergency center's dispatcher.

Note: The regulations regarding the use of defibrillators vary by country and region. It is the user's responsibility to ensure compliance with all relevant laws and regulations.

1.3.4 Intended Use Environment

The device can be used in public places and home healthcare environments.

1.4 Service Personnel Requirements

Service personnel need to be trained and must have thorough knowledge and understanding of the material presented in this User Manual, and they must be authorized by the manufacturer.

1.5 Specifications

- **Model:** The models include A1 and A3 (hereinafter referred to 'the device' unless otherwise specified).

A1 has LED lights, graphic panel and voice prompt, while A3 has an LCD color display, animation, voice and text prompts. They are otherwise the same.

- **Battery:** Non-rechargeable LiMnO₂ battery, capacity of 12V/3000mAh.

1.6 Product Features

The main functions and features of the device are as follows:

Voice and light guidance

The device will guide the operator during use.

A3 uses LCD display, animation, voice and text prompts to guide the operator, whilst the A1 uses LED light, graphic panel and voice prompts.

Rhythm analysis (Accurately differentiate between shockable and non-shockable rhythms)

The device will analyze the heart rhythm automatically when the pads are attached properly.

For pediatric patients, attach the pads to the chest and the back as shown in figure.

Defibrillation (Provide defibrillation treatment)

If the result of the rhythm analysis is '*Shock advised*', the device will automatically charge to the preset energy and the shock button can be pressed for defibrillation. At 50Ω impedance, the rated energy of adult mode released by device is 150J, while child mode is 50J.

Otherwise, the device will automatically enter the CPR stage and provide instructions for the operator.

Self-test system

The system can automatically detect buttons, charge and discharge functions, batteries, and other modules of the device. See Chapter 3.6 for details.

1.7 Product Limitations

The device is an infrequently used device, and has certain limitations as outlined below:



- Daily maintenance is required to ensure the device is ready for use. Please refer to Chapter 5 for details.

2 Safety Precautions

This chapter focuses on the precautions and important hazard warnings to avoid an accident during use. It is important to understand how to use an Automated External Defibrillator (AED) safely. Please read the content below carefully before using the device.

2.1 Classification of Warning Messages

Warning messages are generally divided into 3 categories, as described below:

 Danger	Indicates urgent risks or immediate hazards that will lead to personal injury or even death.
 Warning	Indicates potential risks or risks caused by unsafe operations which could result in personal injury or property damage if not avoided.
Caution	Used to emphasize instructions or reminders so that users can operate this device safely.

2.2 Warning Messages



Danger

- 1) The device generates a high voltage electric shock during defibrillation and may cause severe personal injury (such as myocardial damage) or even death. Therefore, defibrillation should be performed by professionally trained layperson.
- 2) Component replacement can only be performed by the manufacturer. Other personnel must not open the cover to attempt to repair the device or replace components. Otherwise, there is a risk of electric shock.
- 3) Do not disassemble or modify the device. This could result in personal injury or even death.
- 4) Other medical equipment which has no defibrillation-proof applied parts should be disconnected from the patient during defibrillation.
- 5) During defibrillation, keep distance from the patient and remove all metal equipment connected to the patient. Failure to do so may result in an electric shock.



Danger

- 6) There may be a danger of electrocution or injury if the defibrillation energy is not released normally.
 - 7) Do not use the device in an environment with flammable gases or concentrated oxygen to prevent fire or explosion.
 - 8) Do not charge the battery. Charging the battery may cause a fire or explosion.
 - 9) Do not burn or incinerate the battery. Burning or incinerating a battery may cause a fire or explosion.
 - 10) Do not perform maintenance on the device during use.
 - 11) Do not remove the battery when the device enters the rescue mode or when the device is placed in public places.
-
-



Warning

- 1) Only professionally trained personnel who are familiar with the operation of the device can perform emergency defibrillation.
 - 2) Ensure the device is carefully placed to avoid damage to the pads or device, or injury to the patient or operator during use.
 - 3) The device should be placed and affixed in a position that prevents it from falling or dropping. If the device falls or is dropped, it must be checked immediately for any damage.
 - 4) Do not use expired or dry pads as they can not completely adhere to the skin, which will affect the heart rhythm analysis and cause misjudgment.
 - 5) Do not repeatedly and rapidly charge and discharge the device except as necessary during emergency treatment of a patient. If the device test requires repeated internal discharges, wait at least one minute after every three discharges.
 - 6) Do not connect the pads to other pads or metal objects in contact with the patient. It is recommended to keep a distance of at least 5 cm. The conductive gel coating on the pads may stick to other objects. Defibrillation with insufficient gel may cause a skin burn under the pads.
 - 7) Before defibrillation, shave any body hair from the patient's chest if necessary. Excessive body hair may cause skin burns.
 - 8) Do not wipe the patient's skin with alcohol. Alcohol wipes will dry the skin and cause skin burns.
 - 9) Sensitivity of the device may be reduced in patients with cardiac pacemakers. A pacemaker may also reduce the detection of all shockable rhythms by the AED. If you know the patient has a cardiac pacemaker, do not place the pads near the implanted device.
-



Warning

- 10) Do not use the device if the device has been soaked with liquid or lots of water can be seen on the surface of the device. The conductive part of the device must not be in contact with other conductive parts (including the ground).
- 11) When the device is connected to the patient, do not perform any functional checks to avoid accidental electric shock.
- 12) Do not use alcohol or other solutions to soak or clean the pads. This may damage the pads and cause the device to malfunction.
- 13) Moving or carrying the patient during rhythm analysis can cause diagnostic delays or errors.
- 14) Pads should be placed on a flat skin surface instead of on the wrinkled skin surface, inappropriate placement will affect the heart rhythm analysis, which can result in misinterpretation.
- 15) When using the device, the operator must keep the patient's body (such as exposed skin or head and limbs) away from touching conductive fluids (such as gel, blood or saline) and metal objects (such as a bed frame or a stretcher), to prevent alternate pathways for the defibrillation current.
- 16) Do not place the device near any apparatus that emits strong Radio-Frequency (RF) signals. Radio frequency emissions can cause incorrect analysis of heart rhythms.
- 17) Do not use unapproved pads, batteries, and other accessories. The use of unapproved components can cause the device to malfunction. Use accessories only specified by the manufacturer in Appendix 1.
- 18) The device cannot work if the battery is empty and/or uninstalled. Replace the battery immediately if low battery or battery overdue is detected.
- 19) If the device is taken out from the highest storage temperature or the lowest storage temperature and put into use immediately, the performance and service life of the device may differ from expectations. The device must not be stored or used outside of the environmental limits specified in this manual.
- 20) Improper operation may cause runtime errors. Please follow this manual carefully.
- 21) Only service personnel should configure the device for Bluetooth and other specialized tools. The use of Bluetooth will not result in any risk to the device or its operation.
- 22) If the status indicator of the device is off, replace the battery to restore the device. This might be due to the battery failure.
- 23) The user should report any serious incident that has occurred in relation to the device to the manufacturer and the competent authority of the Member State in which the user is established.
- 24) The device cannot be used in an MRI environment.
- 25) Keep the device out of reach of children and pets to avoid the risk of inhalation or swallowing of small parts or strangulation by pads cables.



Warning

- 26) Do not use the standard battery other than its intended purpose, otherwise this may result in a low battery.
 - 27) Call the emergency rescue number in which the rescuers still don't know how to use the AED after reviewing the quick reference guide on the AED label.
 - 28) For adult patients, do not perform chest compression on top of the electrodes.
-

Caution

- 1) If any damage occurs to the device, please contact the manufacturer for repair.
 - 2) Please pay attention to all caution and warning signs on the device and accessories.
 - 3) If the device is stored, transported or used outside the limited range, the performance specifications in this user manual may not be reached.
 - 4) The device can be operated at 50°C, but it is recommended to use it below 40°C to avoid patient burns.
 - 5) It is recommended to provide at least one extra set of pads for each device available in a public place.
-

2.3 Placement of the Device

The device should be placed near emergency equipment (e.g., fire extinguishers, first aid kits) in a suitable environment, away from moisture and dust. To ensure correct placement of the device:

- The ambient temperature should be between 5°C and 50°C for long-term storage. Extreme temperature fluctuations may shorten battery life and affect pad performance.
- Store in a dry area with 5% to 95% humidity, with no condensation.
- Keep the device away from direct sunlight, as prolonged exposure accelerates aging.
- Ensure the speaker is not blocked by lint or dust.
- Do not place the device near a strong magnetic field.

2.4 Side Effects

Based on clinical data from post-market surveillance of the subject device, no side effects have been reported. A literature review of similar devices and SOTA evaluation identified potential undesirable effects, including skin burns, skin reactions, skin rash, and interaction with pacemakers.

3 Installation and Preparation

This chapter mainly introduces the components and appearance structure of the device, the functions of the buttons and indicators of the control panel, and the installation of key components.

3.1 Unpacking

To ensure the integrity of the device, carefully take out all components from the packing case and follow the steps below:

- 1) Check the device shell is intact.
- 2) Check the seal and expiration date of the pads.
- 3) Check the expiration date of the battery.

3.2 Product Overview

This chapter describes the components, control panel and screen display of the device.

3.3 Components

The device consists of the main unit, battery and pads. Please ensure that all components are ready before use.

3.3.1 Control Panel

The A1 control panel is shown below:

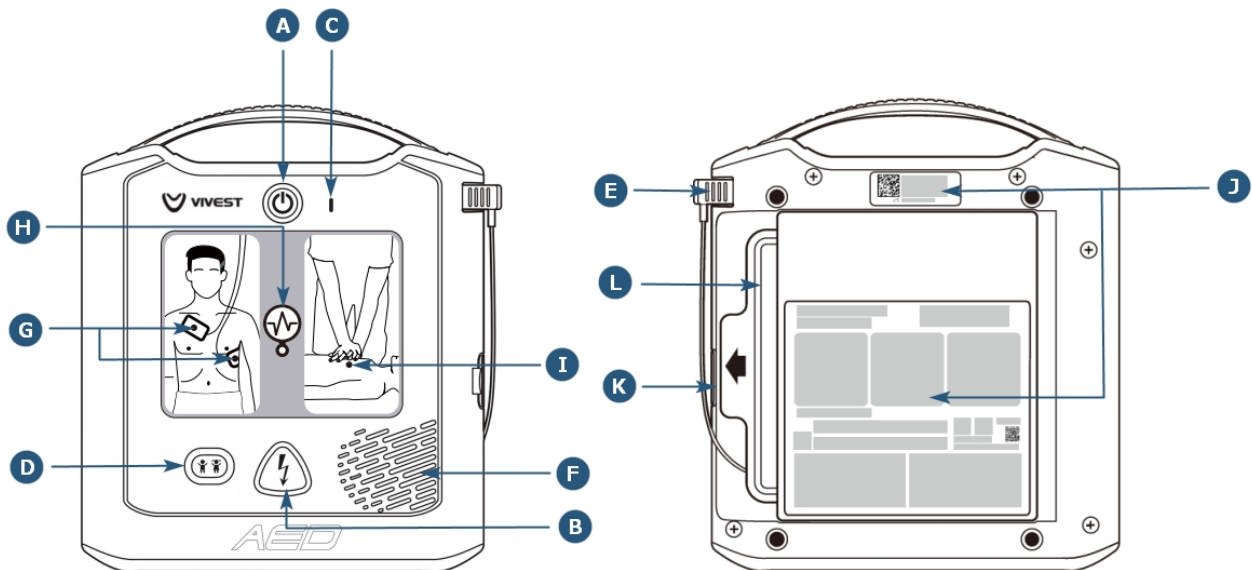

Figure 3-1 A1 front and back panel introduction

The graphic description:

Name	Description
A: Power Button	In standby mode, press this button to enter rescue mode; In rescue mode, press the button for at least 3 seconds to shut the device down and return to the standby mode.
B: Shock Button	This button will flash when the charge is completed and can be pressed to deliver electric shock to patient.
C: Status Indicator	A flashing green light indicates that the device is normal. A flashing red light indicates that the device is faulty.
D: Child Button	Press the button, and the device will prompt: 'To enter Child mode, press the Child button for 3 seconds.' Hold the button for 3 seconds to switch to Child mode. To switch back to Adult mode, shut down and restart the device.
E: Pads Cable Connector	The pads cable connector (hereafter calls "pads connector") will be pre-connected with the main unit.
F: Speaker	Sends voice prompts or beep sounds.
G: Pads Indicator	This light is always on when the device is activated but the pads are not attached to the patient's chest or there is poor adhesion.
H: Heart Rhythm Analysis Indicator	This light is turned on when the device is analyzing the heart rhythm or charging/waiting for the shock to be released. This will indicate "Don't touch the patient".
I: CPR Indicator	When the device enters the CPR stage, the light is always on.
J: Device Label	The device label includes the device identification number, etc.
K: USB Interface	This is used to export data, assist software upgrades and set up parameters (for service personnel only).
L: Pads	Disposable universal electrodes.

The A3 control panel is shown below:

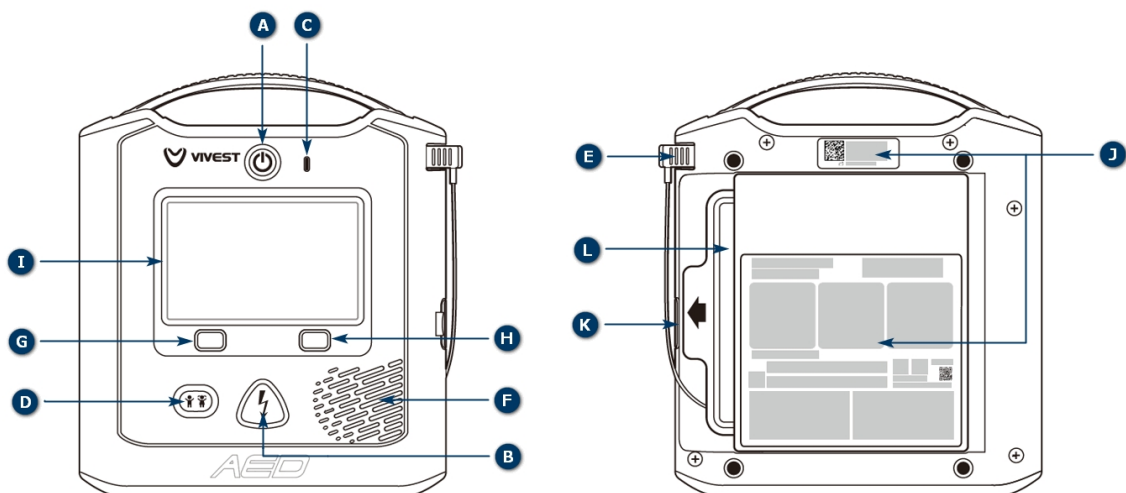

Figure 3-2 A3 front and rear panel introduction

The graphic description:

Name	Description
A: Power Button	In standby mode, press this button to enter rescue mode. In rescue mode, press the button for at least 3 seconds to shut the device down and return to the standby mode.
B: Shock Button	This button will flash when the charge is completed and can be pressed to deliver electric shock to patient.
C: Status Indicator	A flashing green light indicates that the device is normal. A flashing red light indicates that the device is faulty.
D: Child Button	Press the button, and the device will prompt: 'To enter Child mode, press the Child button for 3 seconds.' Hold the button for 3 seconds to switch to Child mode. To switch back to Adult mode, shut down and restart the device.
E: Pads Cable Connector	The pads cable connector (hereafter calls “pads connector”) will be pre-connected with the main unit.
F: Speaker	Sends voice messages or beep sounds.
G: Info Soft Button (Left)	In rescue mode, pressing this button will prompt the operator through the rescue steps.
H: Language Soft Button (Right)	In rescue mode, pressing this button will switch the device between the two present languages.
I: LCD Screen	Shows animation and text prompts.
J: Device Label	The device label includes the device serial number and other information.
K: USB Interface	This is used to export data, assist software upgrade and set up parameters (for service personnel only).
L: Pads	Disposable universal electrodes.

3.3.2 Screen Display

The A3 screen display as follows:



Figure 3-3 A3 screen panel

The graphic description:

Name	Description
A: Number of shocks	Shows the total number of current shocks.
B: Info Icon	Corresponds to the left info soft button on the panel.
C: Language switching Icon	Corresponds to the right language soft button on the panel.
D: Battery power	Shows the percentage of remaining battery power.
E: Patient type	Shows current patient type (adult/pediatric)
F: Time	Shows the running time

3.4 Install or Remove the Battery

The device uses a non-rechargeable LiMnO₂ battery. At 20°C, a fully charged battery can deliver 200 ± 10 charge/discharge cycles with an effective energy of 150J. Battery life may vary based on environmental conditions and usage. Caution: Frequent use may shorten battery life.

3.4.1 Install the Battery

To install the battery, insert the end of the battery into the device's battery slot, then push it fully into place. Ensure the battery buckle is securely inserted into the slot. Once the battery is installed, the device will automatically start the self-test, as detailed in Chapter 3.6.

3.4.2 Remove the Battery

When the '**Low Battery**' prompt appears, replace the battery as soon as possible. To remove the battery, first ensure the device is in standby mode. If the device is in rescue mode, press and hold the power button for more than 3 seconds to enter standby mode. Then, press the battery buckle and pull the battery out.

3.5 Connect the Pads

Check whether the pads connector is connected to the socket. If not, follow the instructions below to connect the pads.



Figure 3-4 Insert the Pads connector

Before connecting the pads, check the seal and expiration date on the package. Do not use the pads if the package is damaged or the pads are expired; replace them immediately. Then, insert the pads connector into the socket and ensure it is fully inserted.

 Warning	<ol style="list-style-type: none"> 1) Never use damaged, wrinkled or folded pads, which may result in current leakage and cause burns on skin. 2) Don't reuse the disposable pads. Repeated use may cause performance degradation or cross infection.
---	---

3.6 Self-test System

The device provides manual self-test, battery installed self-test, power-on self-test and periodic self-test.

Self-test Type	Description
Manual self-test	Service personnel authorized by manufacturer can run manual self-test if necessary.
Battery installation self-test	As soon as the battery is installed, the device will run a self-test. The device will then enter the standby mode after all checks are complete.
Power-on self-test	The device will run a self-test before use when the power is on. This will notify the operator of any failures identified during the self-test
Periodic self-test	Periodic self-test will be carried out daily, weekly, monthly and quarterly. The device will run a self-test automatically according to the default self-test time. The default daily self-test time is 3 am.

Caution	The device will only run an automatic self-test at the preset time in standby mode when the battery is installed.
----------------	---

In standby mode:

- If the device passed the self-test, the status indicator will flash green, indicating it is ready for use.
- If the device failed the self-test, the status indicator will flash red, and the device will beep indicating that the device must be repaired. Please contact the manufacturer.

4 Use Automated External Defibrillator (AED)

 Warning	<ol style="list-style-type: none">1) Do not touch or shake the patient in the process of cardiac rhythm analysis as it will affect the result.2) Nobody should touch the patient during defibrillation!3) The pads must be placed flat on the patient's skin. Not doing so may lead to incorrect heart rhythm analysis and misinterpretation of defibrillation.4) Leaving bubbles between the pads and the patient's skin when attaching the pads may result in burns.5) Make sure the pads have good contact with the patient's body, as poor contact might cause skin burns.
---	--

4.1 Brief Operation Steps

1 Evaluate the patient	<p>Call for help immediately after confirming that the patient has both of the following conditions:</p> <ul style="list-style-type: none">• Unresponsive• Not breathing or breathing abnormally
2 Turn on the device	<p>Press the power button to turn on the device.</p> <p>★Voice prompt: <i>Call for help</i></p>
3 Check the patient type	<p>The device is powered on by default in adult mode (age 8 and above, or weight 25kg and above). If the patient is a child, press the child button and hold the child button for 3 seconds to enter the child mode (age 8 and below, or weight 25kg and below).</p> <p>★Voice prompt: <i>To enter child mode, press the child button for 3 seconds</i> <i>Child mode</i></p>

4 Patient preparation



Remove the patient's upper clothing:

- Make sure the skin is clean and dry
- Shave excess hair if necessary

★Voice prompt:

Remove clothing

5 Pads preparation



Take out the pads package from the back of the device, tear open the package to take out the pads, and then remove the liner from the pads.



★Voice prompt:

Remove pads package from back of AED

Tear open package, take out the pads

Remove Liner from Pads

6 Attach the pads

Follow the directions to attach to the pads.

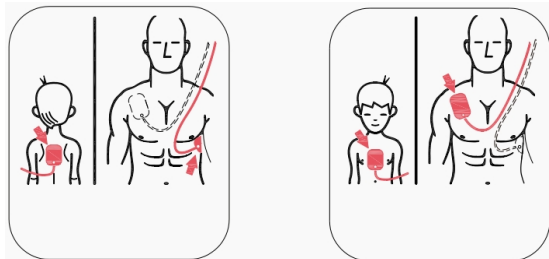

★Voice prompt:

Apply pads to patient's chest

7 Heart rhythm analysis

Do not touch the patient, wait for the device to analyze the heart rhythm.

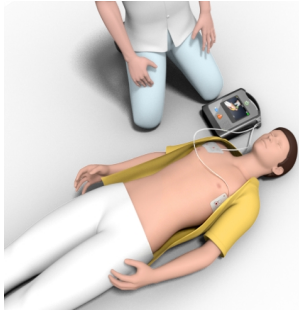

★Voice prompt:

Don't touch patient, analyzing heart rhythm

8 Shock advised

When the device detects a shockable heart rhythm, do not touch the patient, press the flashing shock button.



★Voice prompt:

Shock advised

Don't touch patient, press flashing shock button

Shock delivered

9 No shock advised

If the device does not detect a shockable heart rhythm, go to Step 10.

★Voice prompt:

No shock advised

10 Perform CPR

Perform CPR according to the device prompt.



★Voice prompt:

Begin CPR

Du-Du-Du...

Breathe-breathe

Du-Du-Du...

4.2 Operation After Use

After rescue, perform the following steps:

- 1) Press the power button for 3 seconds to enter the standby mode.

- 2) Clean the device if necessary. Refer to chapter 5.1 for details.
- 3) Replace new pads.
- 4) Check the remaining battery power and replace battery if necessary.
- 5) Put the device back in its original location.

5 Maintenance and Troubleshooting

This chapter describes the daily maintenance, transport, disposal, and troubleshooting of the device. Some of those operations should be guided by authorized service personnel.

5.1 Daily Maintenance

The expected service life of the device is 10 years. In order to ensure the reliability of the device, service personnel should carry out routine maintenance and inspection of the device during the service period.

The device minimizes required maintenance by using extensive self-tests to simplify the maintenance process. The device will monitor its essential performance automatically during use and run periodic self-test automatically in standby mode. Refer to Chapter 3.6 for details.

By visually checking the status indicator every day, the service personnel will know whether the device has passed the self-test within the last 24 hours and confirm whether the device is ready for use. To calibrate the impedance and check the accuracy of discharge energy, please contact the manufacturer.

Maintenance Content	Daily	Monthly	After Rescue
Check the status indicator	✓	✓	✓
Check device and accessories status	✓	✓	✓
Replace the pads	/	/	✓
Check battery power and expiration date	/	/	✓
Manual self-test	/	/	✓
Export data by USB device	/	/	✓



Warning

A series automated defibrillator has **NO** user-serviceable components. All Components of the device can only be replaced or renewed by the manufacturer. No other person must open the cover to repair the device and replace components, otherwise, there is a risk of electric shock.

5.1.1 Check Pads

The pads are disposable. The service personnel should check the package of pads daily to ensure integrity of seals and validity of expiration date.

- Check whether the pads package is damaged. If damaged, replace the pads immediately.
- Check whether the pads are expired. If expired, replace the pads immediately.
- Check whether the pads connector has been inserted. If not, insert it into the connector socket.

In addition, the device can detect the validity period of the pads through self-test. If the pads have expired, the status indicator will flash red in standby mode.

5.1.2 Check the Standby Status Indicator

The device standby status indicator is located at the top center of the panel, and indicates the status of device.

- The flashing green light indicates that the device is in normal state and ready to use.
- The flashing red light indicates that the device has failed the self-test and needs maintenance. Please contact the service personnel or manufacturer as soon as possible.

5.1.3 Check Integrity and Cleanliness

- Check the integrity of the device, refer to chapter 3.2.1.
- Check whether the handle of the device is intact.
- Check whether the device is dusty or dirty, especially the pads connector and pads connector socket.
- Check whether the appearance of the device has scratches or any other marks of damage, especially near the pads connector and pads connector socket. If any scratches or damage are found, contact the manufacturer for maintenance.

5.1.4 Check Battery

The device can detect the remaining battery power and expiration date of the battery through self-test. If expired or has low power, the status indicator will flash red in standby mode. Please replace immediately.

In addition, service personnel should check the battery power and expiration date after a rescue has finished.

5.1.5 Cleaning

The cleaning agents available are:

- Water
- Ethanol 96%
- Sodium hypochlorite (chlorine bleach 3% solution in water)

Please remove dust and dirt on the surface of the device regularly. It is recommended to clean it every three months, or increase the frequency of cleaning according to the usage frequency of the device.

When cleaning, follow these steps:

- 1) Turn off the power, take out the battery and pull out the defibrillation pads.
- 2) Use a clean, soft, non-abrasive cloth to absorb some detergent. Do not splash detergent on the device.
- 3) Wipe the shell, handle and screen of the device.
- 4) Wipe off excessive detergent with a dry cloth.
- 5) Place the device in a cool and well-ventilated place for at least 30 minutes.
- 6) Make sure the device is completely dry, then install the battery and pads.

Caution	Do not clean the accessories (Battery, Pads).
----------------	---

5.2 Battery Maintenance

Battery capacity is consumed during standby, during AED operation, and every time the A series defibrillator is used. If the battery is not used for many years during the service life, the battery capacity will gradually decrease. The AED monitors the amount of charge remaining in the installed battery pack. When the battery capacity is low or depleted, the A series defibrillators will not operate according to specifications. When a low battery level occurs, the AED performs one of the following actions:

- Audible beep from AED five times every hour, with five seconds between each beep. (if AED is off).
- Issued a *"Low battery, replace battery"* prompt (if the AED is on).
- Status indicator flashing red, indicating low battery or other self-test failure.

Battery icon/condition	Indication	Correction
Low battery with AED off	Audible beep from AED five times every hour, with five seconds between each beep.	Replace battery
Low battery during Power-on self-test	<i>"Low battery, replace battery"</i> prompt	Replace battery
Low battery or other self test failure with AED powered off or during self test	Status indicator flashed red. Status indicator is off indicating failure to operate.	Replace battery. Check or replace defibrillation pads. If the status indicator keeps flashing red, contact VIVEST for service.
Low battery with AED powered on	<i>"Low battery, replace battery"</i> prompt	Replace battery as soon as possible
Dead battery	Status indicator is off indicating failure to operate when AED is off.	Replace battery. If the status indicator remains off, contact VIVEST for service.

5.3 Transport

If it is necessary to transport the device to a maintenance point, the battery must be removed from the device and packaged separately before being shipped with the device. The device can be transported using normal shipping methods, but it must be protected from severe shocks, vibrations and rain and snow during transportation.

5.4 Disposal

When the device has expired, it should be disposed of according to local regulations. If in doubt, contact the local recycling company.

Disposal of the pads and batteries should also comply with the relevant regulations and be recycled or disposed of as required.

5.5 Troubleshooting

Some common failures are listed below. They should be checked one by one in order to troubleshoot the failure. Please contact the manufacturer's designated professional personnel to repair the device.

Failure	Causes	Response	Message
The device cannot be turned on	Battery is not installed	Install the battery	N/A
	Invalid or expired battery	Replace the battery	N/A
	Mainboard error or other factors	Contact the manufacturer for maintenance	N/A
The device suddenly shuts down	Invalid or expired battery	Replace battery	N/A
	Mainboard error or other factors	Contact the manufacturer for maintenance	N/A
The device makes a Beep sound in standby mode	The device found a failure while performing self-test	Contact the manufacturer for maintenance	N/A
Defibrillation charging time is too long	Battery/device failure	Stop using the device and contact manufacturer for maintenance.	N/A
	Insufficient battery	Replace battery	N/A
Voice prompt "Low battery"	Insufficient battery	Replace battery	N/A
The device cancels the charging state automatically during charging.	The pads aren't stuck to the patient's chest.	Attach the pads to the patient's chest	N/A
	Poor contact between pads and patient	Check pads contact on patient's skin	N/A
	Damage of pads, cables, or pads connector	Replace pads	N/A
	Damage of pads socket	Contact the manufacturer for maintenance	N/A
Status indicator light is not on	Insufficient battery	Replace battery	N/A
	Damage of the status indicator	Contact the manufacturer for maintenance	N/A
USB is not working properly	USB device failure	Replace USB device	N/A
	Bad USB contact	Reinsert USB. Contact the manufacturer for maintenance	N/A
	Mainboard error or other factors	Contact the manufacturer for maintenance	N/A
Power-on self-test failed	Defibrillation pads expired	Replace pads	"Pads overdue"
	Low battery	Replace battery	"Low battery"
	Mainboard error or other factors	Contact manufacturer for repair	"Equipment failure"

6 Product Warranty

The manufacturer provides a reasonable warranty service during the warranty period.

When requesting a warranty service, you are obliged to provide proof of purchase from the vendor.

The warranty will be void in the case of:

- Violation of instructions.
- Operation error.
- Improper use or handling.
- Unauthorized personnel have repaired the device.
- Force majeure such as lightning strikes.
- Transport damage due to improper packing when sending back.
- No maintenance.
- Damage due to excessive use (such components include batteries, disposable items, etc.).
- The original accessories were not used.

The manufacturer reserves the right to choose to exclude defects, provide non-defective components, or appropriately lower the purchase price based on product defects.

If the warranty is invalid, the manufacturer will not cover the cost of transportation.

The manufacturer will not be liable for any accidental injury caused by the operator's violation of user manual, misuse, or improper handling.

Legal warranty requirements are not affected by the above situation.

7 Cyber Security

This chapter mainly introduces information about cyber security.

7.1 Runtime Environment

7.1.1 Hardware Environment

- CPU: STM32 series
- RAM: 2 MB
- ROM: flash, 64MB
- Display equipment: LED indicator, LCD display
- I/O equipment: LED, speaker

7.1.2 Software Environment

- Runtime system: FreeRTOS V10.6.0
- Prerequisite software: File system
- Matching software: No need
- Antivirus Software: No need

7.1.3 Network Environment

This device includes maintenance mode and rescue mode.

Under normal circumstances, the operator turns on the device and enters rescue mode. In this mode, the USB interface is not exposed to the operating environment, Bluetooth is off and there is no network environment.

In maintenance mode, service personnel can connect through Bluetooth and USB interface.

Maintenance Mode: BLE5.0

- Network Architecture: CS
- Network Type: PAN
- Bandwidth: 10kbps

Rescue Mode: NO network environment

7.2 Data Interface

The device has 2 data interfaces, including USB interface and Bluetooth.

The USB interface cover is fastened by screws. When needed, use a tool to open the cover to access the USB interface.

7.3 User Access Control System

The device is intended to be used in public, home or medical facilities, and must be operated by trained professionals or emergency responders.

The management organization at the AED deployment site is responsible for maintaining the device to ensure it is operational when needed. Additionally, AED users should be categorized based on their level of training or authorization

User Type	Responsibility	Requirement	Access Rights
Operator	Rescue patients using A1/ A3	Have been professionally trained in defibrillation and first aid.	/
Service personnel	Install the A1/A3 device, connect the device using the specified software to configure parameters, export data, and upgrade the main unit software	Have been professionally trained by the manufacturer and obtained the authorization from the manufacturer.	Configure all the parameters.

Caution	<ol style="list-style-type: none"> 1) The network interface and data interface of the device are not open to end users. 2) Cyber security related operations can only be carried out by or under the direction of the service personnel!
----------------	--

7.4 Data Exchange Mode

7.4.1 Bluetooth Transmission

A1/ A3 in maintenance mode can be verified by authorization to turn on Bluetooth and tool software for data interaction to modify the configuration, upgrade firmware and export data.

In the process of self-test, A1/ A3 can actively initiate data interaction with the data collection terminal through Bluetooth and transmit the self-test data to the data collection terminal. The device will also determine the validity of the data collection terminal and only legitimate data collection terminals are connected

7.4.2 USB Export Data

A1/ A3 only supports USB equipment which is USB 2.0, FAT32 file system, Type-C interface. USB transmission for the exportation of data. Data can be exported are configuration data, ECG data, impedance data, self-check data and run diary, etc.

7.4.3 USB Upgrade Function

A1/A3 supports system upgrades via USB. The upgrade files need to be stored in the USB equipment before upgrading. The device will first verify the file header legitimacy of the upgrade file and check the CRC of the file content to ensure the integrity of the upgrade file while upgrading. If the file is damaged, the upgrade terminal will give a reminder that the upgrade file is damaged and the upgrade is cancelled.

7.5 Security Software

No security software is required for A1/ A3.

7.6 Cyber Security Update

There are no cyber security updates in A1/ A3 that users are required to make.

Appendix 1 Standard Accessories

Component:

Name	Model	Manufacture	Quantity	Unit
Battery (Non-Rechargeable)	D0101001	VIVEST	1	Case













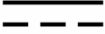

Accompanying Document:

Name	Quantity	Unit
User Manual	1	Copy
Product Certification	1	Copy
Warranty Card	1	Copy
Packing List	1	Copy

Remarks: The component and accompanying document shall be provided to the customer along with the device, and the accurate contents shall be subject to the provisions in the Packing list.

Appendix 2 Symbols

Symbol	Description	Symbol	Description
IP55	The dust and waterproof levels of the device are 5 and 5 respectively		Defibrillation-Proof Type BF Applied Part.
	Stand-by		Battery alarm indication
	Caution. Consult accompanying documentation.		Operating instructions
	Do not dispose of in fire		Do not deform or damage
	Atmospheric pressure limitation		Temperature limit
	Humidity limitation		Keep away from rain
	This way up		Fragile, handle with care
	Stacking limit by number		Use no hooks
	Non-sterile		Do not re-use
	Serial Number		Use by date
	Date of manufacture		Manufacturer
	Part Number		Batch code
	Unique device identifier		Medical Device

Symbol	Description	Symbol	Description
	Follow instructions for use		General warning sign
	Shock button		Child button
	Dangerous voltage		USB
	Direct current		Warning, electricity
	Comply with the EU 2017/745		Authorized representative in the European Community
	Importer		Distributor
	Return the device to a collection site designated for Waste Electrical and Electronic Equipment (WEEE). Do not dispose of it in regular trash.		General symbol for recovery/recyclable

Appendix 3 Glossaries

Glossary	Description
Standby Mode	The device will turn to standby mode after the battery installed.
Rescue Mode	The device will turn to rescue mode when the power button was pressed.
Self-test	The device uses internal procedures to conduct self-detection of the device's own environment and each module of the system.
Defibrillation	The method of shocking the heart with a certain current to stop ventricular fibrillation.
Pads	Contains defibrillation electrode, cable and cable connector.
Pacemaker	An implantable cardiac pacemaker that stimulates the heart with electrical pulses.
Periodic self-test	When the device is in standby mode, daily self-test, weekly self-test, and monthly self-test are performed automatically to detect batteries, internal circuits, buttons, software, etc.
Cardiac arrest	Ventricular fibrillation is the most common cause of sudden cardiac arrest due to sudden termination of ejection function.
Impedance	The device detected the electrical impedance between two pads attached to the patient's skin.
Shockable rhythm	Pulseless ventricular tachycardia or ventricular fibrillation, which can lead to cardiac arrest.
Non-shockable rhythm	The cardiac rhythm identified by the device as unsuitable for electric shock.
Analysis decision time	The time from the start of analysis to the result for identifying shockable rhythm.
Sensitivity	True positive rate (Sensitivity) is the probability of a positive test result, conditioned on the individual truly being positive.
Specificity	True negative rate (Specificity) is the probability of a negative test result, conditioned on the individual truly being negative.
Motion artifacts	Noise caused by muscle movement, cardiopulmonary resuscitation, or static electricity may interfere with cardiac analysis.
New battery	Battery that is well packed, sealed and valid.
Manufacturer	Unless otherwise specified, the company described in this manual is VIVEST.
ECG	Electrocardiogram.
CPR	Cardiopulmonary resuscitation, a technique for rescuing patients in cardiac arrest with artificial respiration and chest compression.
bpm	Beat per minute
AED	Automated external defibrillator

Glossary	Description
EMC	Electromagnetic Compatibility
LED	Light emitting diode
AHA	American Heart Association
SCA	Sudden Cardiac Arrest
AAMI	Association for Advancement of Medical Instrument
USB	Universal serial bus

Appendix 4 Specifications

Safety Specification Features	
Safety classification	Internally powered ME equipment
Protection against electric shock	Defibrillation-Proof Type BF Applied Part.
Protection against harmful ingress of water or particulate matter	IP55
Operational mode	Continuous operation
ME equipment type	Portable
Physical parameters	
Size (including handle)	232±1mm(H)*209±1mm(W)*59±0.5mm(D)
Weight (including battery)	Approx. 1.5kg
Tolerable impact / falling damage	Free to fall from a height of 1.5 m on a hard surface
Service life	10 years (test condition: ambient temperature of 25°C)
Environmental parameters	
Operation temperature	-10°C to 50°C (After entering environment of - 20°C from room temperature, it can work for at least 60 minutes)
Storage temperature	5°C to 50°C
Short term storage/ transportation temperature	-40°C to 70°C (< 7 days)
Relative humidity	5% to 95% no condensation
Air pressure	59.4kPa to 106kPa (-382 meters to +4283 meters)
The time required for the device to warm from the lowest storage temperature between uses until the device is ready for its intended use when the ambient temperature is 20°C	Less than 30 minutes
The time required for the device to cool from the highest storage temperature between uses until the device is ready for its intended use when the ambient temperature is 20°C	Less than 30 minutes
Display (For A3 only)	
Size	105.5mm (H) *65.3mm (W)

Resolution	800×480			
Defibrillation				
Waveform	Truncated biphasic exponential waveform			
Energy level	The rated energy in 50 Ω impedance of adult mode: 150J. The rated energy in 50 Ω impedance of child mode: 50J. (The rated defibrillation energy is settled and cannot be changed.)			
Output control	Manual operation (In rescue mode, the shock button should be pressed by operator).			
Operational impedance limitation of patient	20Ω to 180Ω (The device will inhibit its output when the patient impedance is outside the limit.)			
Charging time (Time required for charging the defibrillation capacitor to 150J under different battery conditions)	Battery Status (In the environment of 20±2°C)	The time from pressing the power button to the time when the defibrillation can be delivered	The time from the initial heart rhythm analysis to the time when the defibrillation can be delivered	The time from the second heart rhythm analysis to the time when the defibrillation can be delivered
	New battery	≤17s	≤11s	≤7s
	New battery, after 6 times of maximum energy discharge	≤17s	≤11s	≤7s
	New battery, after 15 maximum energy discharge	≤17s	≤11s	≤7s
ECG analysis system				
Analysis decision time	≤7s			
Analysis accuracy	Comply with IEC60601-2-4 requirements			
Cardiac arrest threshold	<0.2mV			
Artifacts detection	Support If an interfering signal that affects the accuracy of the heart rhythm analysis is detected, the device will delay performing the analysis and give a prompt.			

Battery	
Battery type	LiMnO ₂ battery, 12V/3000mAh
The number of maximum energy discharges which are available from a new and fully charged battery	New battery can charge and discharge 200±10 times in rated energy of 150J at 20°C±2°C environment.
Battery standby life	5 years (Ambient temperature 20°C±2°C, standby mode with new battery installed, daily self-test)
Battery service life	7 years
Low battery condition	The device can deliver at least 30 shocks after the low battery indication is first displayed.
Pads	
Model	OBS-DE/SC1/a
Pads shelf life	5 years
Specification	Self-adhesive disposable pads with outlet connector.
Length	1.1±0.1m

Appendix 5 Defibrillation Waveform

The defibrillation waveform of the device is a truncated biphasic exponential waveform, and the device can automatically adjust the waveform parameters for the patient impedance in the range of 20 ~ 180 Ω . Defibrillation energy output waveform is shown in the figure below:

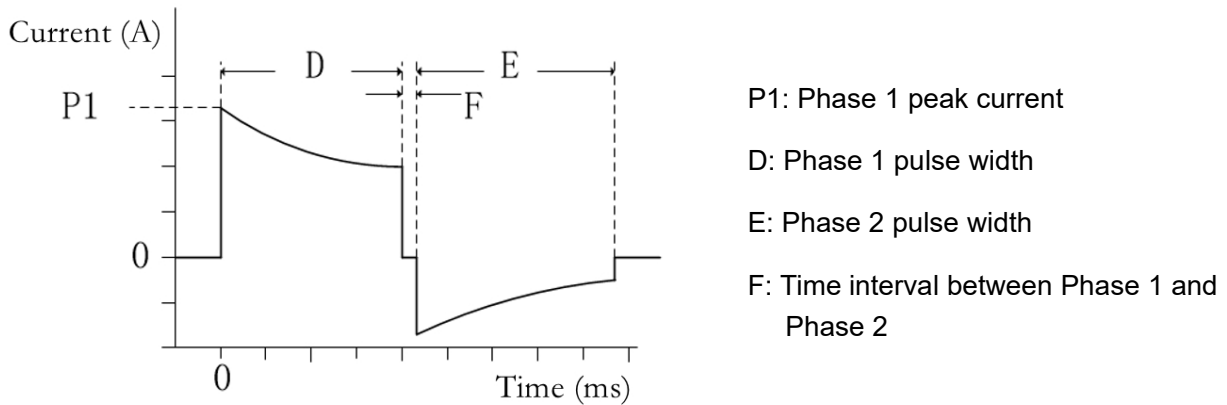

Energy output under various impedances (Adult mode):

Load impedance (Ω)	Phase 1 pulse width D(ms) $\pm 15\%$	Phase 2 pulse width E(ms) $\pm 15\%$	Time interval between Phase 1 and Phase 2 F(ms) $\pm 15\%$	Peak current P1 (A) $\pm 15\%$	Energy output (J) $\pm 15\%$
25	2.8	2.8	0.5	61.0	128
50	4.5	4.5	0.5	33.5	150
75	6.3	5	0.5	23.4	155
100	8	5.3	0.5	18.0	157
125	9.7	6.4	0.5	14.5	158
150	11.5	7.7	0.5	12.0	160
175	12	8	0.5	10.5	158

Energy output under various impedances (Child mode):

Load impedance (Ω)	Phase 1 pulse width D(ms) $\pm 15\%$	Phase 2 pulse width E(ms) $\pm 15\%$	Time interval between Phase 1 and Phase 2 F(ms) $\pm 15\%$	Peak current P1 (A) $\pm 15\%$	Energy output (J) $\pm 15\%$
25	2.8	2.8	0.5	36.0	43.4
50	4.5	4.5	0.5	19.6	50.0
75	6.3	5.0	0.5	13.5	52.0
100	8.0	5.3	0.5	10.3	52.2
125	9.0	6.0	0.5	8.4	52.3
150	9.0	6.0	0.5	7.0	50.0
175	9.0	6.0	0.5	6.0	49.0

Appendix 6 ECG Analysis System

Summarize

The defibrillator's ECG analysis system automatically identifies the patient's heart rhythm and provides shock advice to the operator. It also provides trained operators with guidance on possible lifesaving treatment in the care of cardiac arrest patients. The analysis system has the following functions:

1. Determination of electrode contact
2. Pacemaker signal recognition and removal of the pacing signal
3. Recognition of a shockable heart rhythm
4. Cardiac arrest detection
5. Interference detection

Determination of electrode contact

The defibrillator will automatically detect the thoracic impedance of the patient. If the impedance value is within the set threshold value, the electrode will be judged to be firmly in contact and the heart rhythm analysis can be started. If the chest impedance value exceeds the set threshold, the electrode is judged to have inadequate contact or to be improperly connected to the defibrillator, at which point the operator is advised to re-insert the electrode.

Pacemaker signal recognition and removal of the pacing signal

The pulse signal of a buried pacemaker may interfere with the correct identification of arrhythmias. The defibrillator will first identify and erase the pacing signal and then enter into the rhythm analysis. Based on the results of the analysis, the shock or no shock prompt is given.

Recognition of a shockable heart rhythm

According to the requirement for heart rhythm recognition detector consist in clause 201.107 of IEC 60601-2-4:2018, the performance of heart rhythm recognition detector and classification of heart rhythm recognition detector are as follows:

Table A6-1 Performance of heart rhythm recognition detector

Rhythms	Sample Size	Performance Goal of IEC60601-2-4	Observed Performance
Shockable		Sensitivity	
VF	726	>90%	100%
VT	368	>75%	99.7%
Non-shockable		Specificity	
	3350	>99%	99.7%

Table A6-2 Classification of heart rhythm recognition detector

Rhythms	VF and VT	All other rhythms
Shockable	True positive 99.7%	False positive 0.3%
Non-shockable	False negative 0.3%	True negative 99.7%

*Data Source: International standards databases and VIVEST clinical collection databases

The results showed that a total of 4444 data were collected, including 3350 non-shockable data, with a specificity of SP-99.7%, and 1094 shockable data, VF with a sensitivity Se-100%, VT with a sensitivity of Se-99.7%. The positive prediction rate was Pp-99.7%, the false positive rate was Fp-0.3%, and the accuracy was Acc-99.7%. The performance of the heart rhythm recognition detector meets the performance requirements of various rhythm types and quantities in IEC60601-2-4, and the sensitivity or specificity of each rhythm type meet the requirements of IEC60601-2-4.

Cardiac arrest detection

Pause threshold is peak-peak 0.2mV. Be careful that the electrical signal peak-peak is less than 0.2mV, the system will recognize the pause and give a warning that electric shock is not recommended, and CPR will be initiated.

Interference detection

The defibrillator’s ECG analysis system detects interference, which may be caused by external sources such as posture movements or electrical noise. Postural movement includes: patient movement, rescuer movement, vehicle movement, etc.; External sources of electronic noise: e.g., mobile phones, radios, etc. If interference is detected, the system sends a voice warning to the rescuer, at which point the operator should remove the interference as soon as possible to minimize artifacts in the ECG, and the system continues to perform heart rate analysis.

Appendix 7 Electromagnetic Conformity Guide

 <p>Warning</p>	<ol style="list-style-type: none">1) Use of accessories, transducers and cables not manufactured by the manufacturer could result in increased electromagnetic emissions or decreased electromagnetic immunity of this device and result in improper operation.2) Use of this device adjacent to or stacked with other equipment should be avoided because it could result in improper operation. If such use is necessary, this device and the other equipment should be observed to verify that they are operating normally.3) The EMC of this device needs to be specially protected, and it needs to be installed and repaired in an environment that meets EMC information below.4) Even if other equipment meets the CISPR emission requirements, they may cause interference to the device.5) Other equipment that contains RF radio emissions may affect the device (for example, mobile phones, wireless-enabled computers).6) In the presence of large EM disturbance, the device may unexpectedly prompt “Eliminate Signal Interference”, “Keep Patient Still” or “Poor Pad Contact”, and may not be unable to perform analysis. Please turn off the interference source or move away from it.7) Portable RF communications equipment (including peripherals such as antenna cables and external antennas) should be used no closer than 30 cm (12 inches) to any part of the device, including cables specified by the manufacturer. Otherwise, degradation of the performance of this equipment could result.
---	--

ESSENTIAL PERFORMANCE:

The essential performance of A3/A1 is delivery of defibrillation therapy and accurately differentiate between shockable and non-shockable rhythms.

Electromagnetic Emissions		
A1/A3 is intended for use in the electromagnetic environment specified in the tables below. The user of the device should ensure that it is used in such an environment:		
EMISSIONS TEST	COMPLIANCE	ELECTROMAGNETIC ENVIRONMENT-GUIDANCE
Radio-frequency emission CISPR 11	Group 1	The A1/A3 uses RF energy for its internal functions only. Therefore, its RF emissions are low and may not cause any interference in nearby electronic equipment. The A1/A3 is suitable for use in all establishments, including domestic establishments and those directly connected to the public low-voltage power supply network that supplies buildings used for domestic purposes.
Radio-frequency emission CISPR 11	Class B	
Harmonic distortion IEC61000-3-2	N/A	
Voltage fluctuations and flicker IEC61000-3-2	N/A	

Electromagnetic Immunity			
A1/A3 is intended for use in the electromagnetic environment specified in the tables below. The user of the device should ensure that it is used in such an environment:			
IMMUNITY TEST	IEC 60601 TEST LEVEL	COMPLIANCE LEVEL	ELECTROMAGNETIC ENVIRONMENT - GUIDANCE
Electrostatic Discharge (ESD) IEC 61000-4-2	±2Kv,±4kV, ±6kV, ±8kV contact ±2Kv,±4kV, ±8kV, ±15kV air	±8kV contact ±15kV air	The relative humidity should be at least 5%
Power Frequency (50/60Hz) Magnetic Field IEC 61000-4-8	30A/m	30A/m	The power frequency magnetic fields should at levels characteristics of a typical location in a typical commercial/hospital environment.

Electromagnetic Immunity

A1/A3 is intended for use in the electromagnetic environment specified in the tables below. The user of the device should ensure that it is used in such an environment:

IMMUNITY TEST	IEC 60601 TEST LEVEL	COMPLIANCE LEVEL	ELECTROMAGNETIC ENVIRONMENT - GUIDANCE
Radiated RF IEC 61000-4-3	10V/m 80MHz to 2.7GHz	20V/m 80MHz to 2.7GHz	<p>Portable and mobile RF communication equipment should be used no closer to any part of the A1/A3, including cables, than the recommended separation distance calculated from the equation applicable to the frequency of the transmitter.</p> <p>Recommended separation distance: $d = 1.2\sqrt{P}$ 80MHz to 800MHz $d = 2.3\sqrt{P}$ 800MHz to 2.7GHz where P is the maximum output power rating of the transmitter in watts (W) according to the transmitter manufacturer and d is the recommended separation distance in meters (m). Field strengths from fixed RF transmitters, as determined by an electromagnetic site survey^a, should be less than the compliance level in each frequency range. Interference may occur near equipment marked with the following symbols: </p>

Note 1: At 80MHz and 800MHz, the higher frequency range applies.

Note 2: These guidelines may not apply in all situations. Electromagnetic propagation is affected by absorption and reflection from structures, objects and people.

^a Field strengths from fixed transmitters, such as base stations for radio (cellular/cordless) telephones and land mobile radios, amateur radio, AM and FM radio broadcast and TV broadcast cannot be predicted theoretically with accuracy. To assess the electromagnetic environment due to fixed RF transmitters, an electromagnetic site survey should be considered. If the measured field strength in the location in which the A1/A3 is used exceeds the applicable RF compliance level above, the device should be observed to verify normal operation. If abnormal performance is observed additional measures may be necessary, such as reorienting or relocating the device.

IMMUNITY to RF wireless communications equipment				
Test frequency (MHz)	Band ^{a)} (MHz)	Service ^{a)}	Modulation	IMMUNITY TEST LEVEL (V/m)
385	380 to 390	TETRA 400	Pulse modulation ^{b)} 18 Hz	27
450	430 to 470	GMRS 460, FRS 460	FM ^{c)} ±5 kHz deviation 1 kHz sine	28
710	704 to 787	LTE Band 13, 17	Pulse modulation ^{b)} 217 Hz	9
745				
780				
810	800 to 960	GSM 800/900, TETRA 800, iDEN 820, CDMA 850, LTE Band 5	Pulse modulation ^{b)} 18 Hz	28
870				
930				
1720	1700 to 1990	GSM 1800; CDMA 1900; GSM 1900; DECT; LTE Band 1,3,4,25; UMTS	Pulse modulation ^{b)} 217 Hz	28
1845				
1970				
2450	2400 to 2570	Bluetooth, WLAN, 802.11 b/g/n, RFID 2450, LTE Band 7	Pulse modulation ^{b)} 217 Hz	28
5240	5100 to 5800	WLAN 802.11 a/n	Pulse modulation ^{b)} 217 Hz	9
5500				
5785				
<p>If necessary to achieve the IMMUNITY TEST LEVEL, the distance between the transmitting antenna and the ME EQUIPMENT or ME SYSTEM may be reduced to 1 m. The 1 m test distance is permitted by IEC 61000-4-3.</p>				
<p>a) For some services, only the uplink frequencies are included. b) The carrier shall be modulated using a 50% duty cycle square wave signal. c) As an alternative to FM modulation, the carrier may be pulse modulated using a 50% duty cycle square wave signal at 18 Hz. While it does not represent actual modulation, it would be worst case.</p>				

IMMUNITY to proximity magnetic fields		
Test frequency	Modulation	IMMUNITY TEST LEVEL (A/m)
30 kHz ^{a)}	CW	8
134.2 kHz	Pulse modulation ^{b)} 2.1 kHz	65 ^{c)}
13.56 MHz	Pulse modulation ^{b)} 50 kHz	7.5 ^{c)}
<p>a) This test is applicable only to ME EQUIPMENT and ME SYSTEMS intended for use in the HOME HEALTHCARE ENVIRONMENT.</p> <p>b) The carrier shall be modulated using a 50% duty cycle square wave signal.</p> <p>c) r.m.s., before modulation is applied.</p>		

Appendix 8 Additional Information

Clinical Benefits

Provide analysis of shockable rhythm or non-shockable rhythm and deliver the shock with the shockable rhythm to improve the survival chance for patients with SCA.

Incident Reporting

If the user or patient needs to report any serious incidents in relation to the device, they can contact the manufacturer and the competent authority of the Member State where the user and / or patient is established.

Information Available to The User

The user manual is provided with the device in a paper format.

The SSCP will be available on EUDAMED.

<https://ec.europa.eu/tools/eudamed>

Regulatory Compliance

VIVEST solemnly declares that A1/A3 complies with the relevant provisions of the relevant medical equipment standards:

IEC 60601-1:2005+AMD1:2012+AMD2:2020 CSV - Medical electrical equipment - Part 1: General requirements for basic safety and essential performance.

IEC 60601-2-4:2018 - Medical electrical equipment – Part 2-4: Particular requirements for the basic safety and essential performance of cardiac defibrillators

IEC 60601-1-2:2014+AMD1:2020 CSV - Medical electrical equipment - Part 1-2: General requirements for basic safety and essential performance - Collateral Standard: Electromagnetic disturbances - Requirements and tests.

IEC 60601-1-12:2014+A1:2020 CSV - General requirements for basic safety and essential performance - Collateral Standard: Requirements for medical electrical equipment and medical electrical systems intended for use in the emergency medical services environment

IEC 60601-1-11:2015+A1:2020 Medical electrical equipment — Part 1-11: General requirements for basic safety and essential performance — Collateral standard: Requirements for medical electrical equipment and medical electrical systems used in the home healthcare environment

Appendix 9 Compatible Accessories

Name	Model	Manufacture
Disposable Multifunction Electrodes	PADS-AT05	FIAB
External Defibrillation Pads	OBS-DE/SC1/a	Baisheng

 Warning	<p>The pads manufactured by FIAB cannot be used on patients who is under 12 months of age or less than 10kg.</p>
---	--